

FORD TOURNEO CONNECT 2015-

TR	Montaj Talimatı	:	PORT BAGAJ
GB	Fitting Instructions	:	ROOF RACK
D	Montageanleitung	:	DACHRELING
F	Instructions de Montage	:	RIDELLES DE TOIT

TR

*Port bagaj taşıma kapasitesi 75 kg. olup; yükleme yapmadan önce aracın tavan taşıma kapasitesinin dikkate alınması gerekir.

GB

*Roof Rack carrying capacity is maximum 75 kg. Please check your vehicle roof maximum carrying capacity from your car manufacturer before load roof rack.

G

*Maximale Traglast unsere Dachrelinge betragen 75kg. Die freigegebenen Dachlasten der Fahrzeughersteller dürfen nicht überschritten werden. Bitte zur Kenntnisnahme!

F

*La capacité de chargement maximale est de 75 Kg. Nous vous prions de vérifier la capacité de chargement du toit de votre véhicule avant de charger les barres de toit.

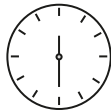

30 Min.



M2627930_Rev03
29.11.2023

PARÇA LİSTESİ

Part List / Teileliste / Lista de accesorios

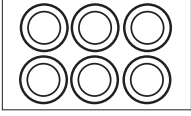

- TR M6 PUL = 6 PARÇA
- GB M6 RING WASHER = 6 PIECES
- D M6 UNTERLEGSCHLEIBE = 6 STUCK
- F M6 RONDELLE AUTOBLOQUANTE = 6 PIECES

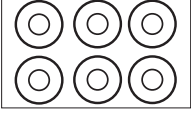

- TR M8 PUL = 6 PARÇA
- GB M8 RING WASHER = 6 PIECES
- D M8 UNTERLEGSCHLEIBE = 6 STUCK
- F M8 RONDELLE AUTOBLOQUANTE = 6 PIECES

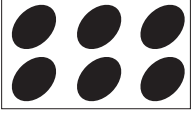

- TR PLASTİK TAPA = 6 PARÇA
- GB PLASTIC PLUG = 6 PIECES
- D GUMMISTOPFEN = 6 STUCK
- F BOUCHON PLASTIQUE = 6 PIECES

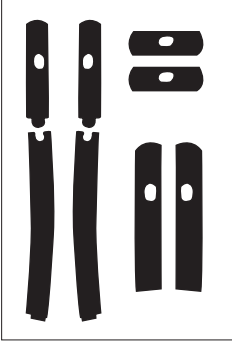

- TR AYAK PLASTİKLERİ = 8 PARÇA
- GB FOAM PLASTIC = 8 PIECES
- D SCHAUM KUNSTSTOFF = 8 STUCK
- F MOUSSE PLASTIQUE = 8 PIECES

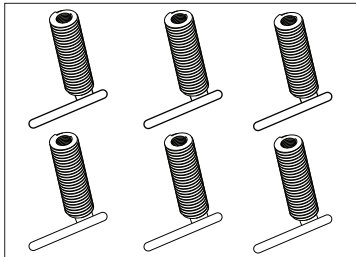
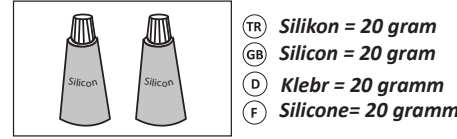
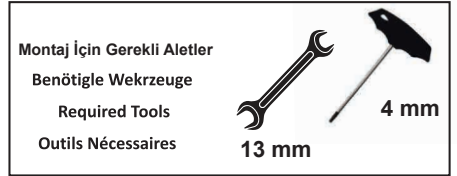
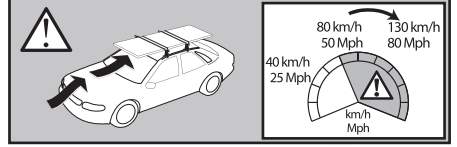
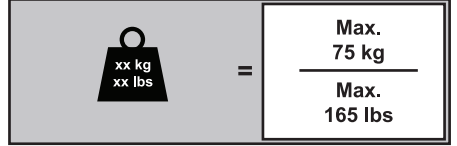

FRONT - MIDDLE - REAR - (M8 - M5) 6 PCS.

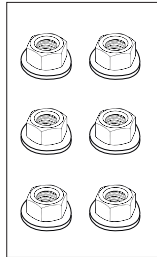

M8 (FRONT - MIDDLE - REAR 6 PCS.)

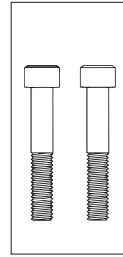

M5 x 55 (MIDDLE - 2 PCS.)

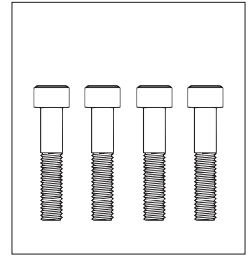

M5 x 45 (FRONT - REAR - 4 PCS.)

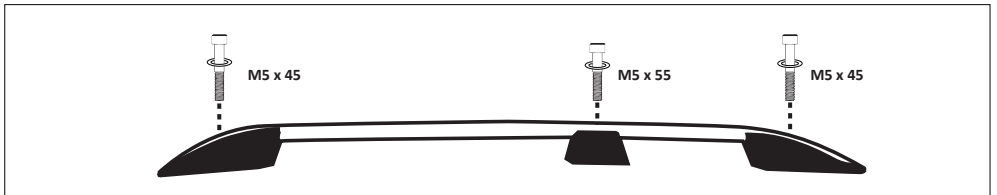

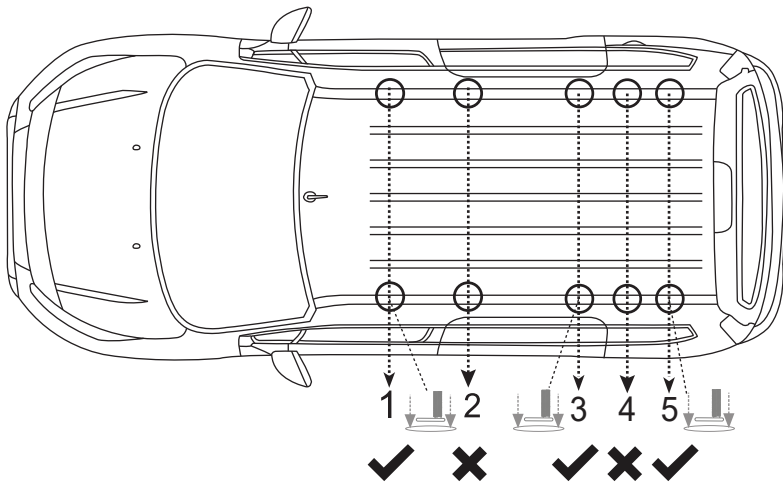

1) 1,3 ve 5 Numaralı tapalar araç üzerinden sökülüp özel yapım civataları M8 flanslı somun ile sıkın. Civataların etrafını silikonla kapatın.

1) Please remove the shown caps (numbered as 1,3 and 5) and tighten the specific production screws by M8 flanged nut. Then cover around by silicon glue well.

1) Bitte entfernen Sie die markierten Kappen (als 1,3 und 5 nummeriert). Im Nachhinein Befestigen Sie diese mit spezialangefertigten Schrauben "M8 Flanschmutter" fest. Zum Schluss den Decken rundherum mit Silikonkleber verkleben.

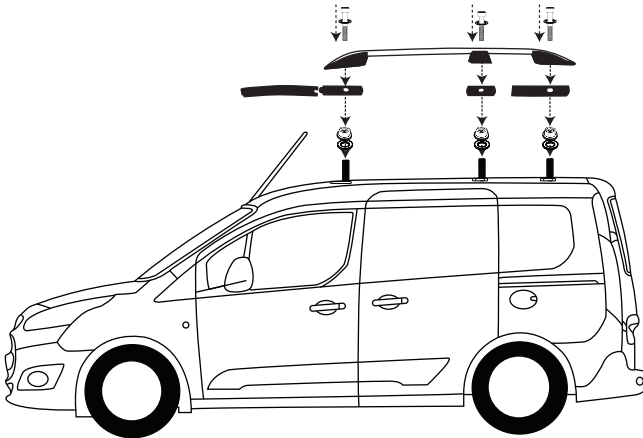
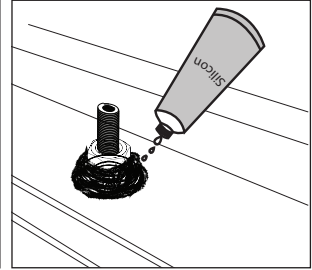
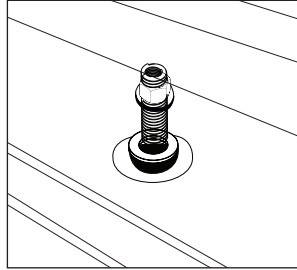
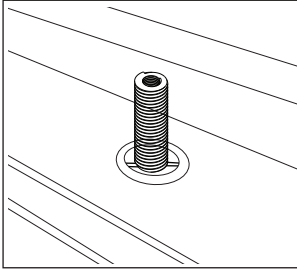

2) Kapı fitilinden tavan döşemesi sökülerek civata yukarı doğru geçirilip üstten somun ile sıkılacaktır.

2) Please remove the window seal and pull the headline down to find right position, then place the screw and tighten by the nut on top.

2) Entfernen Sie die Fensterdichtung (Oberhalb) danach setzen Sie die Schraube in die richtige Position und ziehen Sie diese mit einer Mutter fest.

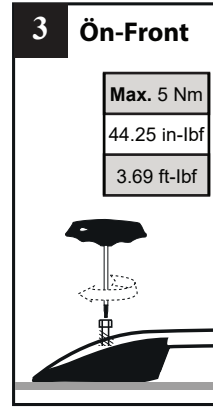
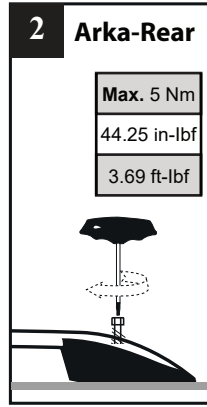
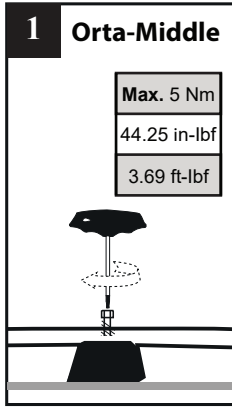

3) Port Bagajı araç üzerine montaj yerlerinden sabitleyip 1,2,3 nolu civatalar sırasıyla eşit şekilde maximum 5 Nm olarak araç üzerinde merkezleyerek sıkınız.

3) Fix the roof rail at the mounting points on top of the vehicle then start turning the screw bolts in the following order (Bolt #1, Bolt #2, Bolt #3) and turn the bolts by putting equal force, maximum 5 Nm.

3) Positionieren Sie die Dachreling an den Befestigungspunkten oben auf dem Fahrzeugdach und beginnen Sie dann, die Schraubenbolzen in der folgenden Reihenfolge zu drehen (Schraube #1, Schraube #2, Schraube #3) und drehen Sie die Schrauben mit gleicher Kraft, die maximale Kraft sollte 5 . betragen Nm.

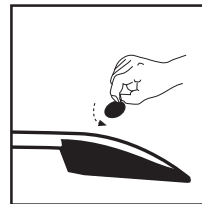
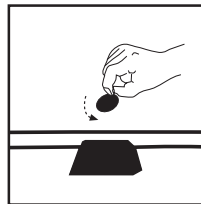
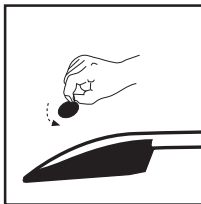

4)Port Bagajın tapalarını yerlerine yerleştirerek montajı tamamlayınız.

4)Tap the plugs on roof rails.

4)Stecken Sie die Stopper in Ihre Plätze und schließen Sie diese.